

A Framework for Ubiquitous IP Communications in Vehicle to Grid Networks

Sandra Céspedes*[†] and Xuemin (Sherman) Shen*

*Department of Electrical and Computer Engineering, University of Waterloo, Waterloo, Canada

[†]Department of Information and Communications Technology, Icesi University, Cali, Colombia
{slcesped,xshen}@bbcr.uwaterloo.ca

Abstract—The electrical grid is a critical infrastructure that is slowly moving towards a more reliable and efficient supply system: the Smart Grid. As part of this migration process, a new group of energy-aware and emission-free technologies are being developed. Electric vehicles are a promising technology that belongs to that group. By connecting the electric vehicles to the grid, an energy-efficient cycle is created, in which the vehicles not only draw power from the grid, but they also send electricity back into it. For a successful vehicle to grid (V2G) interaction, a reliable and ubiquitous V2G communications network should be deployed. While previous research has focused on V2G data transmission when the vehicle is connected to the grid, we focus on the advantages of enabling the exchange of data while on-the-go by means of a wirelessly connected smart metering infrastructure network. Furthermore, this paper proposes a complete framework for the support of IP communications in mobile V2G environments. We perform simulations based on realistic channel models for smart metering networks to evaluate the performance of the proposed framework, and demonstrate the feasibility of IP communications as a promising platform for the deployment of innovative V2G applications.

I. INTRODUCTION

Smart electric networks, also known as Smart Grid, are a set of technologies that enable an efficient electricity supply system and a better distribution of the available electricity power. Energy-aware technologies, on the other hand, aim at promoting the use of more renewable and distributed electricity generation. For example, electric vehicles are an energy-aware technology that can provide a great source for energy power, which could be employed to power homes and offices, or could create a large battery system for balancing the fluctuating electric system. Therefore, by connecting the electric vehicles to the Smart Grid, an energy-efficient cycle is created, in which the vehicles not only draw power from the grid, but they also send electricity back into it. Consequently, Vehicle to Grid (V2G) networks are considered a promising component in the evolution toward an efficient and sustainable electric system.

Apart from connecting electric vehicles to the Smart Grid for power distribution purposes, there is also the necessity of creating a reliable and ubiquitous V2G communications network. In this way, the electric vehicles can benefit from the exchange of information with the utility or the intermediary

entity acting as an aggregator, in order to make informed decisions about recharging costs, battery management, or automated billing [1]. Similarly, the V2G network also enables the vehicles to send information to the utility or to the aggregator, such as readings from battery consumption or their preferred locations for charging stations. Furthermore, if the V2G communications network is IP-compliant, then it will open the door for innovative applications that address the specific market of electric vehicles users. Such applications can be offered by content providers other than the local utility company, and can exploit the infrastructure supporting V2G communications.

Examples of those applications are battery management profiles that calculate the best times and frequencies for battery recharging, given the vehicle's consumption history and the electric market prices [1]. The vehicles could send information about their current battery charge status while on-the-go, and the application would respond with on-the-go recommendations for the drivers to administrate their batteries at their best convenience. A web-based version of the same application could be available online for the times when consumers want to access their information or update their profiles using a regular Internet connection. The V2G network architecture supporting IP services is illustrated in Fig. 1. By supporting IP services, the V2G network may use well-known IP-based technologies and may readily be connected to other IP-based networks.

Nevertheless, IP-based technologies were not designed for energy efficient environments. As a matter of fact, technologies that enable communications in the Smart Grid, such as IEEE Std 802.15.4 [2], only support physical layer frame sizes up to 127 bytes in order to maintain low-power consumption (they are also consider low-rate networks), whereas a typical IPv6 packet is 1280-byte long. As a result, new adaptation layers are needed to compress and enable transmissions of IPv6 packets over constrained networks [3]. Moreover, new challenges arise with the incorporation of the electric vehicles fleet, regarding its IP configuration and mobility management.

This paper is concerned with the incorporation of a mobile component into the Smart Grid, for which transparent and ubiquitous IP communications over the constrained network are enabled. The contributions of this paper are twofold: 1) the specification of a framework (i.e., block components, protocols, and technologies) required for IPv6 support in V2G communications; and 2) the evaluation, by means of simulation, of the framework's performance for different V2G applications data rates and channel conditions. With this work,

©2011 IEEE. Personal use of this material is permitted. Permission from IEEE must be obtained for all other uses, in any current or future media, including reprinting/republishing this material for advertising or promotional purposes, creating new collective works, for resale or redistribution to servers or lists, or reuse of any copyrighted component of this work in other works.

Accepted in Globecom'11 Workshop - UbiCoNet

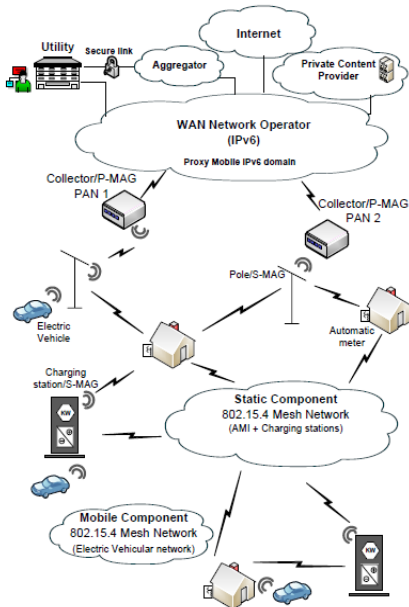

Fig. 1. V2G communications network

we intend to motivate further research in the development of innovative applications for V2G communications.

The remainder of this paper is organized as follows: section II discusses the related work in V2G applications, and the current technologies and standards employed for communications in the Smart Grid. In section III, we describe our system model and the different block components of the proposed framework. Sections IV and V introduce our proposal for an IP-compliant V2G communications network and the simulation evaluation. Finally, concluding remarks are provided in section VI.

II. RELATED WORK

The migration to the Smart Grid has become a requisite to be addressed by utilities, at the same time that governments have started to create policies that make such migration mandatory. For example, the Energy Independence and Security Act of 2007 mandated smart grid construction in the USA. Similarly, in 2009, the European Parliament established mandatory migration to smart metering to be completed by 2022. Communications in the Smart Grid, on the other hand, may be supported by different technologies such as Power Line Communications (PLC), IEEE 802.15.4 wireless technology, and text messaging over cellular networks.

The integration of electric vehicles to the Smart Grid has also been addressed by different standardization bodies. In [4][5], Smart Grid communications and interoperability issues, as well as recommended practices for the interconnection of electric vehicles to the Smart Grid are provided.

In general, communication technologies in the Smart Grid are constrained by low-data rates, lossy, and low-power conditions. PLC communications are a straightforward solution that enables data transmission through the electric network. In [6], a communication stack for IPv6 over PLC is proposed. PLC, however, does not meet the requirements of a V2G communications network, in which vehicles may send information

on-the-go to the utility or an external IP network. In [7], the authors address the problem of connecting plug-in electric vehicles to the Smart Grid, by using cellular networks and text messaging. Although this solution allows to use existent infrastructure, text messaging impose a strong restriction over the quantity and quality of information to be sent. This could potentially affect the deployment of innovative applications in the V2G context.

IEEE 802.15.4 [2], on the other hand, is a popular low-cost technology often employed in wireless sensor networks, which has also become popular in Smart Grid deployments. The technology offers the advantages of wireless communications: nearby buildings that have 802.15.4-equipped smart meters connect wirelessly to each other to form a mesh, rural areas can be integrated to the Smart Grid at a relatively low implementation cost, and mobile components such as an electric vehicles fleet can be easily connected through the same technology. In fact, the 802.15.4g amendment intends to improve this technology capabilities specifically for Smart Utility Networks [8]. Therefore, we consider 802.15.4 as the base technology for communications in our system model.

IPv6 support in wireless sensor networks powered by 802.15.4 has come at a later stage. Initially, the sensor network was not thought for direct connection to IP networks. If a connection was necessary, translation gateways were proposed to make the connection possible [9]. As a result, the IETF has been working on defining standards for the support of IPv6 data packet transmission over 802.15.4 [3], and for other related protocols such as Neighbor Discovery [10]. Other technical challenges applicable to wireless sensor networks in terms of energy efficiency, reliability, and security can be found in [11].

The problem of IP address configuration and IP mobility in 802.15.4 networks has been addressed by means of adapting host-based and network-based mobility protocols [12][13][14]. However, they do not provide specific details for the initial address configuration, and the connections are often limited to the one-hop neighborhood. Moreover, their main focus is e-health scenarios, in which patients with 802.15.4 sensors move around the hospital facilities. Therefore, this paper focus in the interaction of 802.15.4-equipped electric vehicles with the Smart Grid, and in the detailed definition of IP support in this context.

III. SYSTEM MODEL

Consider an Automated Metering Infrastructure (AMI) network installed in a city scenario, such as the one illustrated in Fig. 1. The AMI is formed by automated meters equipped with 802.15.4 wireless radios that send periodical readings to the collector. The 802.15.4 radios connect with each other in a mesh fashion, and poles are employed as repeaters to close gaps in areas difficult to reach by house-to-house connections. Electric vehicles and charging stations connect to the mesh network also by means of 802.15.4 radios.

Collectors are distributed along the city. Each collector acts as a coordinator for the group of nodes inside a specific geographic area. Areas correspond to WPANs as defined by [2]. Collectors then connect to a wide area network (e.g., LTE, WiMAX, or WiFi hotspots), which in turn provides connection to the utility and other IP networks.

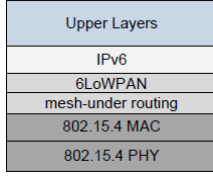

Fig. 2. V2G stack of protocols

Nodes equipped with 802.15.4 radios have the stack of protocols depicted in Fig. 2. We assume there is a mesh-under routing protocol that enables data forwarding in the mesh network. Mesh-under means that routing is performed in a sub-IP layer. The 16-bit short addresses assigned by the collector at the moment of association are used for forwarding, hence, routing uses link-layer identifiers instead of IP addresses. We also assume that link-local addresses are created based on EUI-64 addresses that are globally unique.

In order to keep the complexity as low as possible in the electric vehicles, and also to reduce the energy consumption, vehicles may configure default routes pointing to gateways instead of running the mesh-under routing protocol. We explain this configuration in section IV.

On top of the routing protocol, there is the 6LoWPAN adaptation layer [3]. This layer is required to compress IPv6 packets to a size suitable to be transferred through the AMI. On the other hand, the IP layer performs IPv6 packets encapsulation and is supported by an on-demand version of the Neighbor Discovery (ND) Protocol. The on-demand ND is inspired by the work in [10]. However, we modified that work so that ND messages are triggered only when needed, and some mechanisms such as Duplicate Address Detection are completely avoided.

For managing the IP-based communications, we propose an IP mobility management scheme based on Proxy Mobile IPv6 (PMIPv6) [15]. PMIPv6 performs localized network-based mobility, so that the signalling required for maintaining global IP addresses is kept at the network side. As explained in the PMIPv6 standard, the Mobile Access Gateway (MAG) detects new connections in the one-hop neighborhood, and notifies these events to the Local Mobility Anchor (LMA). The LMA then assigns network prefixes for each node in the domain. When a handover occurs, the new MAG signals the mobile node information to the LMA, which in turn recognizes the mobile node (by using a unique identifier), and maintains the same IP prefix assignment.

PMIPv6, however, is not designed for multi-hop scenarios such as the mesh topology in the AMI network. Nevertheless, network-based mobility shifts the burden of the signalling to the entities located at the infrastructure side, which means that mobile nodes do not need to include any special protocol in their stack. Therefore, it meets our goal of keeping a low-complexity stack in the electric vehicle.

Consequently, we define a special low-power/mesh-enabled PMIPv6 that considers the network characteristics of the AMI. Our mesh-PMIPv6 employs a regular LMA for assigning IP prefixes to the electric vehicles. The LMA also guarantees the uniqueness of the assigned global IP addresses. In order to support multi-hop in the mesh, we split the functionalities

of the MAG into two different entities: the serving-MAG (S-MAG) and the portal-MAG (P-MAG).

The S-MAGs run in charging stations and poles. They detect the connection of a new vehicle to the network, or the vehicle's intra-WPAN and inter-WPAN movements. The S-MAG delivers the WPAN-ID in beacon messages that are periodically sent for network discovery purposes, as specified in [2]. It is also in charge of associations at the link-layer as a delegate from the WPAN coordinator (i.e., the collector). On the other hand, the P-MAG is the one in charge of notifying the LMA about new/moved connections, according to the messages received from the S-MAG. It exchanges the regular PBU/PBA messages with the LMA for a proper tunneling of IP packets directed to the electric vehicle.

The details of the signalling mechanisms for IP configuration, maintenance, and mobility are described in detail in the following section.

IV. ENABLING IP COMMUNICATIONS IN V2G NETWORKS

For initializing IP communications, a vehicle first should join a WPAN upon reception of network discovery beacons from an S-MAG. In such case, the vehicle also sets the 16-bit short address of the S-MAG as the default mesh-under router. The S-MAG, upon the vehicle's successful association, proceeds to initiate the mesh-PMIPv6 signalling toward the P-MAG. A simplified PBU, which includes only the mobility options for source link-layer address and identifier of the vehicle, is sent first from S-MAG to P-MAG. Note that the association may also trigger the sending of a multicast Router Solicitation (RS) message from the vehicle. If the S-MAG receives an RS, it sends a simplified PBU only if it has not yet been sent as a result of the association. Otherwise, the RS is ignored.

Upon reception of the simplified PBU, the P-MAG exchanges PBU/PBA with the LMA, and proceeds to send a unicast Router Advertisement (RA) message with the IP prefix information for the vehicle. The RA is forwarded through the mesh until the S-MAG finally delivers it to the vehicle. Upon RA reception, the vehicle configures a global IP address, and sets the P-MAG as the IP layer default router.

We use pre-established IP tunnels between LMA and P-MAGs (i.e., the collectors). Therefore, an entry in the LMA's binding cache indicates the tunnel end-point that is currently active for a newly assigned (or a recently handover) IP prefix. Since the LMA guarantees a unique prefix assignment and the EUI-64 is globally unique, the duplicate address detection mechanism is completely avoided. The initialization process is summarized in Fig. 3.

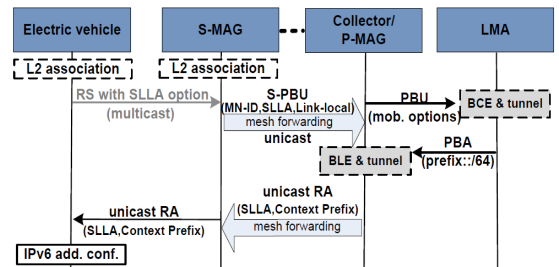

Fig. 3. IP initialization in a V2G network

Note that RS messages are multicast only in the one-hop domain. RA messages, on the other hand, are unicast and are not sent periodically. ND timers are configured so that vehicles keep their global IP prefix configuration unless a neighbor unreachability detection fails to communicate with the P-MAG.

Intra-PAN and Inter-PAN Handover

V2G communications usually take place when a vehicle is stationary, for example, when recharging batteries at the charging station, or parking at work or home driveway during the night. However, there are times in which the vehicle is moving and may need to deliver information to the network, in order to inform battery status changes or other periodic information. Therefore, we need to address the problem of IP mobility, so that the vehicle is able to initiate communications without having to re-configure the IP address every time it moves to a new location. Since our goal is to maintain low-power consumption, we do not trigger location update procedures unless the vehicle intends to send a data packet (in some cases, the neighbor unreachability detection may be configured to happen at a low-rate. Such messages may also trigger location updates).

Two different types of movements are considered: 1) intra-WPAN, when the vehicle moves through S-MAGs belonging to the same WPAN; and 2) inter-WPAN, when the vehicle moves through S-MAGs belonging to different WPANs. In the former case, the vehicle keeps receiving beacon messages that announce the same WPAN-ID, so no changes are informed to the IP layer and no neighbor unreachability messages need to be sent, only the default mesh-under router is updated. If the vehicle intends to send a data packet, it sends the data packet with the format and control information specified in Fig. 4. The S-MAG then forwards the packet to P-MAG, as indicated in the mesh-header destination field. From there, the packet is tunneled toward the LMA, from where is finally routed to the external destination.

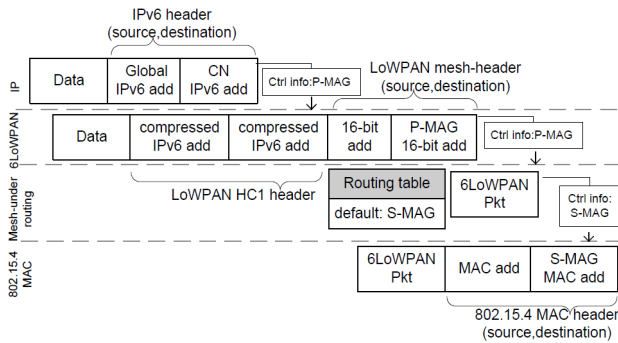

Fig. 4. Data packet encapsulation in a V2G network

The inter-WPAN handover is indicated by the reception of a beacon message with different WPAN-ID. Once the association is completed (i.e., a new 16-bit short address is assigned to the vehicle), the vehicle performs neighbor unreachability detection by sending a Neighbor Solicitation (NS) message to the P-MAG. The S-MAG, however, has

initiated the location update upon association, so that the IP tunnel can be properly updated to the new P-MAG. The new P-MAG responds with a unicast RA in which the same router's link-local address and IP prefix are announced to the vehicle. In this way, the vehicle does not detect any changes at the network layer. Note that a unicast RA is equivalent to an RA with the solicited flag; therefore, the RA is processed as a positive response to the previously sent NS message. The inter-WPAN handover process is summarized in Fig. 5.

The delivery of on-demand ND and mesh-PMIPv6 packets rely on the mesh-under routing protocol performance. We suggest to employ the movement detection hints in order to update the paths to reach the vehicle in its current location. However, the specific procedures by which the paths are updated in the routing protocol are out of the scope of this paper. In the following section we evaluate the performance of our proposed framework.

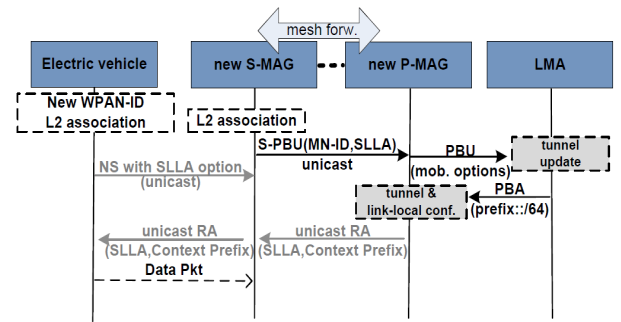

Fig. 5. Inter-WPAN handover in a V2G network

V. PERFORMANCE EVALUATION

The proposed framework has been implemented with the Omnet++ and MiXiM network simulation tools. Vehicles and S-MAG communicate using MiXiM's 802.15.4 MAC and PHY modules, while the static component of the mesh network is simulated with a channel that accounts for delay and packet losses reported for mesh-under routing protocols running in AMI environments [16]. The experiment involves a vehicle moving at an average speed of 35Km/h through a path in which poles and charging stations are uniformly distributed. Intra-WPAN and inter-WPAN handovers occur approximately every 1Km and 2Km respectively.

We implemented the stack illustrated in Fig. 2 in the vehicle, S-MAG, and P-MAG. P-MAGs and LMA connect through a channel that experiences 5ms delay. Since the 802.15.4 MAC module in MiXiM is a non-beacon CSMA/CA, we implement a beacon procedure employed exclusively for network discovery purposes, as indicated in [2]. The beacon interval is indicated by $aBaseSuperFrameDuration \times 2^{macBeaconOrder}$ symbols, where $aBaseSuperFrameDuration = 960$ and $macBeaconOrder$ is a value configurable between 0 and 14. The symbol duration is $16\mu s$.

The mesh network has transmission rate of 250Kbps, 40ms average delay from meters to collector, and 98% average packet delivery ratio [16]. Mobile connections suffer from path losses that follow a log-distance model governed by $PLd_0 - 10 \times pathLossExponent \times \log_{10}(distance/d_0) + X_g$,

where $PLd_0 = -55dBm$, $pathLossExponent = 2.4$, $d_0 = 1m$, and $X_g \sim normal(0, 4)$. The thermal noise and sensitivity are set to $-110dBm$ and $-105dBm$ respectively. The 802.15.4 radios use 40mW for transmission power and work at the 2.4GHz frequency band.

Fig. 6(a) shows the packet delivery ratio of our framework for different application data rates. Three different channel conditions are employed: ideal (i.e., packet error rate is 0 for wireless and mesh transmissions), realistic wireless channel (i.e., log-distance path loss model in the wireless segment), and realistic AMI network (i.e., path loss model in wireless segment and 2% packet error rate in the static AMI). The purpose of this test is to evaluate the impact of the 802.15.4 network on the framework's performance.

It can be seen from the figure that a nearly perfect PDR is achieved under ideal conditions. However, the lossy conditions of the AMI network reduces the PDR around 11% in average when packet losses occur in both wireless and static segments. Nevertheless, almost 90% PDR is achieved for the less demanding data transmission rate (1pkt/2min), which corresponds to a realistic data rate employed in Smart Grid environments. This percentage can be further improved by increasing the PDR achieved by the routing protocol in the mesh network.

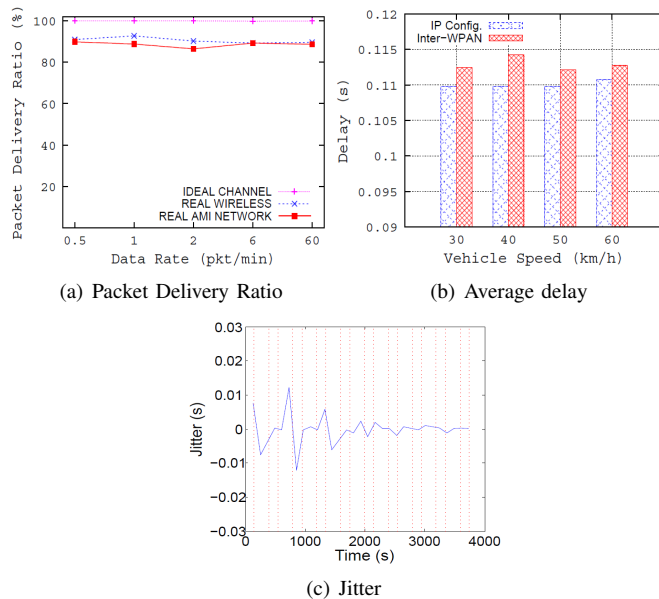

Fig. 6. Performance evaluation of IP communications framework for V2G

The average initial IP configuration delay and handover delays for different vehicle's average speeds are depicted in Fig. 6(b). We evaluate the worst-case scenario, in which the vehicle triggers the neighbor unreachability detection procedure every time it detects a change of WPAN. The intra-WPAN handover delay was not included since it is reduced to zero in our scheme. This is the result of splitting the MAG functionalities between S-MAG and P-MAG, so that no changes of the IP tunnel are necessary while the vehicle roams in the same WPAN. The similarity between the IP configuration and intra-WPAN handover delays are due to the generation of RS and NS messages. In both cases, they require the reception of an RA to resume the sending of data packets. Nevertheless, a

typical V2G application will hardly be affected by this value, since it is in the order of 100ms.

In Fig. 6(c) we provide the jitter experienced by the uplink traffic during the first 4000s. The vertical dashes represent the times at which inter-PAN handover take place. Note that, although high jitter occurs during the first 2000s, it tends to stabilize with time, and no degradation occurs due to the changes of point of attachment. Moreover, high jitter values are also the result of weak communications conditions due to channel path loss model employed during the simulations.

VI. CONCLUSION

In this paper, we have introduced a novel framework for enabling IP communications in a Vehicle-to-Grid communications network. The main technologies for V2G communications have been identified and a stack of protocols for the support of IP-based services in V2G has been proposed. We have also introduced protocols necessary to launch the IP address configuration and IP mobility through the V2G network. Since V2G networks are supported by energy-aware technologies, the proposed protocols aimed at low-power consumption and low-complexity. Simulation results have demonstrated the feasibility of the deployment of IP communications in V2G networks, with a reduced IP configuration and handover delay.

REFERENCES

- [1] A. N. Brooks, "Vehicle-to-Grid Demonstration Project: Grid Regulation Ancillary Service with a Battery Electric Vehicle," AC Propulsion, Inc, Tech. Rep. 01, 2002.
- [2] "IEEE Std 802.15.4-2006," *IEEE Std 802.15.4-2006 (Revision of IEEE Std 802.15.4-2003)*, pp. 0_1-305, 2006.
- [3] G. Montenegro, N. Kushalnagar, J. Hui, and D. Culler, "Transmission of IPv6 Packets over IEEE 802.15.4 Networks," *IETF RFC 4944*, 2007.
- [4] National Institute of Standards and Technology US Dept. of Commerce, "NIST Framework and Roadmap for Smart Grid Interoperability Standards, Release 1.0," *NIST Special Publication 1108*, 2010.
- [5] "SAE standard J2847/1 Communication between Plug-in Vehicles and the Utility Grid," *Society of Automotive Engineers International, under development*, 2010.
- [6] C. Chauvenet, B. Tourancheau, D. Genon-Catalot, and P.-E. Goudet, "A communication stack over PLC for multi physical layer IPv6 Networking," in *IEEE SmartGridComm 2010*, pp. 0-5.
- [7] C. Hochgraf, R. Tripathi, and S. Herzberg, "Smart Grid Charger for Electric Vehicles Using Existing Cellular Networks and SMS Text Messages," in *IEEE SmartGridComm 2010*, pp. 167-172.
- [8] IEEE 802.15WPAN Task Group 4g (TG4g) Smart Utility Networks, "IEEE 802.15 Smart Utility Networks (SUN) amendment to 802.15.4," [Online]. Available: <http://www.ieee802.org/15/pub/TG4g.html>
- [9] G. Rao, Z. Suryady, U. Sarwar, and M. Abbas, "A gateway solution for IPv6 wireless sensor networks," in *ICUMT '09*, 2009, pp. 1-6.
- [10] Z. Shelby, S. Chakrabarti, and E. Nordmark, "Neighbor Discovery Optimization for Low Power and Lossy Networks (6LoWPAN)," *Internet draft (work in progress)*, IETF, 2011.
- [11] R. Lu, X. Li, X. Liang, X. Shen, and X. Lin, "GRS: The green, reliability, and security of emerging machine to machine communications," *IEEE Communications Magazine*, vol. 49, no. 4, pp. 28-35, 2011.
- [12] G. Bag, S. M. S. Shams, A. H. Akbar, H. M. M. T. Raza, K.-H. Kim, and S.-W. Yoo, "Network Assisted Mobility Support for 6LoWPAN," in *6th IEEE CCNC*, 2009, pp. 1-5.
- [13] M. Islam, M.M. and Hassan and E.-N. Huh, "Sensor Proxy Mobile IPv6 (SPMIPv6) - A framework of mobility supported IP-WSN," in *13th ICCIT*, 2010, pp. 295-299.
- [14] K. Jin Ho, H. Rim, and H. Choong Seon, "Development of a framework to support network-based mobility of 6LoWPAN sensor device for mobile healthcare system," in *Digest of Technical Papers International Conference on Consumer Electronics*, Jan. 2010, pp. 359-360.
- [15] A. Gundavelli, K. Leung, V. Devarapalli, K. Chowdhury, and B. Patil, "Proxy Mobile IPv6," *IETF RFC 5213*, 2008.
- [16] S. Cespedes, A. Cardenas, and T. Iwao, "Comparison of Data Forwarding Mechanisms for AMI Networks," in *Proc. IEEE ISGT 2012*, Washington, USA.