

# IP Mobility Management for Vehicular Communication Networks: Challenges and Solutions

Sandra Céspedes\*, Xuemin (Sherman) Shen\*, Christian Lazo†

\*Department of Electrical and Computer Engineering, University of Waterloo

†Instituto de Informática, Universidad Austral de Chile

**Abstract**—Vehicular Communication Networks (VCN) have emerged as a promising platform for the deployment of safety and infotainment applications. The stack of protocols for VCN will potentially include Network Mobility Basic Support (NEMO BS) to enable IP mobility for infotainment and Internet-based applications. However, the protocol has performance limitations in highly dynamic scenarios such as those in vehicular networks, and several route optimization mechanisms have been proposed to overcome these limitations. This article addresses the problem of IP mobility and its specific requirements in vehicular scenarios. A qualitative comparison among the existent IP mobility solutions that optimize NEMO BS in VCN is provided. Their improvements with respect to the current standard, their weaknesses, and their fulfillment of specific VCN requirements are also identified. In addition, the article describes some of the open research challenges related to IP mobility in vehicular scenarios.

**Index Terms**—Vehicular networks, NEMO Basic Support, Mobility management, Route optimization (RO).

## I. INTRODUCTION

THE emergence of new applications designed for vehicular environments has triggered an interest in conducting research on VCN. These applications were initially designed for safety-oriented communications, but the role of infotainment applications has rapidly taken an important place. One example of applications on the safety-oriented side is the notification of emergency situations (e.g., car accidents or bad weather conditions). On the other side, examples of infotainment applications go from using vehicle-to-infrastructure (V2I) communications for driver assistance services or for traditional Internet-based applications (e.g., up-to-the-minute traffic reports, assisted parking, and the download of music and video files), to using vehicle-to-vehicle (V2V) communications for distributed games that are played among passengers in neighboring vehicles.

Although the primary objective of VCN is to increase safety for drivers and passengers in vehicular scenarios, the infotainment applications are likely to incentive a faster adoption of the required equipment and supporting infrastructure. Therefore, it is very critical to guarantee seamless, reliable, and ubiquitous communications that provide a satisfactory

user experience to the early adopters. As a result, it becomes necessary to have protocols that facilitate not only the intelligent and secure flooding of information, but also the mobility management of mobile networks such as buses, trains or cars providing connection to their passengers.

VCN are constituted of in-car (On Board Units [OBU]) and on-road (Road Side Units [RSU]) devices with communications, positioning, and computing capabilities (Fig.1). Both the OBU and the RSU incorporate the stack of protocols defined for vehicular communications. The stacks proposed by various standard development organizations include a special set of protocols to handle safety and emergency communications while they include a parallel stack to handle IP-based applications<sup>1</sup>. In this way, general IPv6 traffic and Internet-based applications are also supported in the VCN. In addition to the inclusion of IPv6, the IP mobility has been suggested to be managed by the IETF standards Mobile IPv6 (MIPv6) and NEMO BS [1].

NEMO BS is meant to provide continuous network connectivity to a group of nodes that are moving together, i.e., a mobile network. As depicted in Fig.1, the mobile network is managed by a Mobile Router (MR) that provides connection to the group of nodes (the Mobile Network Nodes [MNN]). Similar to MIPv6, NEMO BS uses the concept of a fixed IPv6 prefix (the Mobile Network Prefix [MNP]) to provide global reachability to the mobile network. When the MR connects to an Access Router (AR) in a visited network, it acquires a topologically valid IP address (Care of Address [CoA]), followed by a registration of this CoA with the Home Agent (HA). Then, the HA creates an entry that directs the traffic destined to the mobile network to be routed to the newly assigned CoA. In this way, NEMO BS establishes a bi-directional tunnel between the MR and the HA, which is used every time a MNN communicates with any Correspondent Node (CN).

Although NEMO BS seems to fit well in the context of terrestrial transport systems, it has not been designed to support the dynamics and special characteristics of VCN. The current version of NEMO BS, as defined in the standard, does not incorporate a route optimization (RO) mechanism, as

©2011 IEEE. Personal use of this material is permitted. Permission from IEEE must be obtained for all other uses, in any current or future media, including reprinting/republishing this material for advertising or promotional purposes, creating new collective works, for resale or redistribution to servers or lists, or reuse of any copyrighted component of this work in other works.

Published in IEEE Communications Magazine.  
DOI:10.1109/MCOM.2011.5762817

<sup>1</sup>Some examples are the stack proposed by IEEE (<http://standards.ieee.org/>) in 1609-IEEE Trial-Use Standard for Wireless Access in Vehicular Environments (WAVE), and the stack proposed by ETSI (<http://www.etsi.org/website/homepage.aspx>) for an integrated standard based on the recommendations of the Car-to-Car consortium and ISO TC 204 WG16 (CALM).

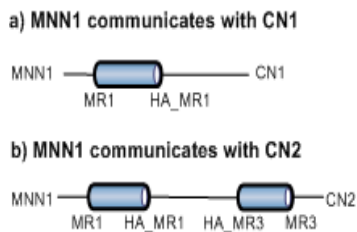

Fig. 2: Examples of tunneling in NEMO BS

its counterpart MIPv6 does, and that affects its performance in vehicular scenarios. In addition, vehicles roaming along heterogenous access networks (i.e., IEEE 802.11p, WiMaX, WiFi, 3G/LTE), as well as multihomed vehicles connecting simultaneously to more than one access network, pose additional challenges to the IP mobility management. Therefore, in this article we examine the specific requirements of VCN in terms of IP mobility, survey and evaluate the existing approaches to improve the performance of NEMO BS by means of RO mechanisms in vehicular scenarios, and outline the emerging challenges. Other surveys in RO for NEMO BS exist<sup>2</sup>, but to the best of our knowledge, none of them focuses on vehicular scenarios.

## II. OVERVIEW OF THE IP MOBILITY IN VCN

In vehicular scenarios, similar to any IP-based scenario that involves mobile networks, a mechanism is required to handle the change of point of attachment to the IP network. With this mechanism, session continuity is provided and the changes are transparent to end users. However, the special characteristics in VCN create unique requirements for IP mobility mechanisms. Some characteristics are high velocities, non-restricted power and processing resources (as opposed to regular MANET), extended area of coverage (city wide, country wide, and world wide), and heterogeneous access networks (e.g., coverage may be provided by 3G/LTE, WiMAX, or WiFi, with some or all of them constituting different administrative domains).

Moreover, the combination of mobile nodes (e.g., passengers' mobile devices) and mobile routers, with independent stacks of protocols and IP mobility mechanisms, and with ability to communicate in ad hoc or infrastructure-based fashion, makes the IP mobility in VCN a challenging task.

NEMO BS, on the other hand, is a potential candidate for providing IP mobility in VCN. However, it is designed to use the tunnel MR-HA every time a MNN communicates with any CN. This can affect the performance of certain applications—specially delay-sensitive ones such as voice over IP—due to the added delay when the two peers use a non-direct path. The sub-optimality of the protocol appears when the distance between CN-MR is smaller than the distance MR-HA. Such example in a NEMO-enabled VCN (Fig.1) is illustrated in Fig.2. For instance, when MNN1 communicates with CN2, the data packets are transmitted first to HA\_MR1 and HA\_MR3, instead of going directly through the path MR1-AR-MR3-CN2.

The problems of NEMO BS are fully documented in RFC 4888 [2]. However, an optimized version is not yet standardized. The optimization of NEMO BS is currently addressed by the IETF working group Mobilty EXtensions for IPv6 (MEXT WG), which evaluates RO mechanisms for different contexts of application<sup>3</sup>.

In general, an IP mobility mechanism should meet the following requirements [3]:

- 1) *Reduced transmission power at end devices*: The end devices' proximity to the MR allows them to use less power-consuming interfaces;
- 2) *Reduced handover events*: The MR should hide the changes of the attachment point from the group of MNNs;
- 3) *Reduced complexity*: The MNNs should not be required to run their own IP mobility protocol. In this way, the complexity at end devices can be reduced; and
- 4) *Reduced bandwidth consumption*: The MR should cluster the signalling required to keep the nodes globally reachable, therefore, consuming less bandwidth resources. Even MIPv6-enabled nodes should benefit from the stable CoA configured from the mobile network prefix.

On the other hand, regardless of the adopted technique to provide RO for the IP mobility mechanism, the technique should efficiently utilize the network resources and improve the network performance, i.e., end-to-end delay, susceptibility to link failures, and data efficiency (overhead/payload relation).

In the particular case of vehicular scenarios, an additional set of requirements to be addressed by NEMO BS and the RO technique are summarized as follows (see draft-ietf-mext-nemo-ro-automotive-req-02 [2]):

- 5) *Minimum signaling*: The RO technique must carry the least possible amount of signaling messages;
- 6) *Separability*: The MR must determine if the RO strategy is enabled in a per-flow basis and according to pre-defined policies. Any information about the CN's location could be relevant to define such policies;
- 7) *Security*: There must be mechanisms to validate the MNP and CoAs ownership claimed by the MR that sends the binding update (BU);
- 8) *Binding privacy protection*: The content of BU (CoAs, MNP) must only be revealed to the entities involved in the tunnel establishment;
- 9) *Multihoming*: The MR must be able to simultaneously connect available egress interfaces to multiple access networks; and
- 10) *Switching HA*: The MR must be able to switch its registration to the closest HA (when available). This is very important given the aforementioned areas of coverage that are possible in vehicular networks.

Furthermore, a vehicle's OBU is likely to have more than one network interface, which means it is able to connect to more than one access network at the same time, as well as to switch between different technologies in order to achieve

<sup>2</sup>See RFC 4889 [2] for a taxonomy of RO models in NEMO

<sup>3</sup>Three possible contexts were identified in the MEXT WG's charter (2007): automotive scenarios, aeronautics and space exploration, and personal area networks. A re-charter document has been adopted in September 2010.

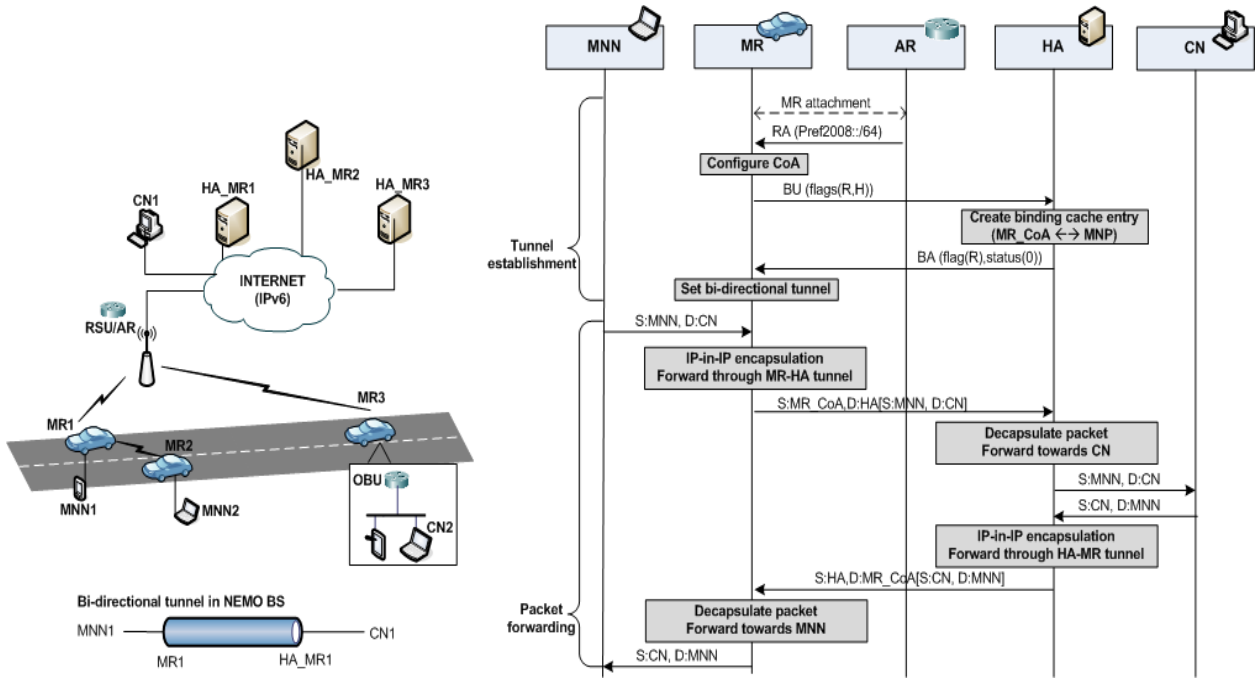

Fig. 1: Operation of NEMO BS in VCN

seamless communications. This heterogeneous nature at the infrastructure side of the VCN pose additional challenges to the IP mobility management mechanism.

On one hand, there is still a lack of fully integration between IP-based and cellular networks, in terms of the entities and signalling employed to provide IP mobility. For example, in traditional 3G networks, a proprietary protocol named GTP is used as part of the IP mobility. In the case of LTE network architecture, there has been efforts to adopt Internet standards in order to comply with the concept of all-IP networks; however, the gap between the protocol elements defined by LTE and the entities defined by MIPv6/NEMO BS has not yet been resolved. On the other hand, for a vehicle roaming at high speeds along dissimilar radio access technologies, the vehicular scenario imposes more strict requirements on the handover latency, especially for fleeting network connectivity such as that offered by WiFi access.

In the following section, we classify the sub-optimality problems of NEMO BS and the RO techniques proposed to solve them. They are evaluated and compared in the context of vehicular scenarios. We also present a survey about RO solutions for NEMO BS that are dedicated to vehicular scenarios and introduce the ongoing research along the line of IP mobility in heterogeneous vehicular access networks.

### III. OPTIMIZATION OF NEMO BS IN VEHICULAR SCENARIOS

To analyze the sub-optimality of NEMO BS, we look at the connection between VCN and the fixed network from two different perspectives: A) by using single-hop connections to reach the fixed network, i.e., the vehicle has direct connection to an access point in the infrastructure (see MR1 in Fig. 1); and B) by using multi-hop connections to reach the fixed network,

i.e., vehicles connect to neighboring vehicles in order to reach the infrastructure (see MR2 in Fig. 1).

When NEMO BS is employed as the IP mobility management mechanism in the first category, packets follow sub-optimal paths to reach the CN due to the pass through the HA before reaching the destination. The use of sub-optimal paths between two peers is a recurrent problem of IP mobility solutions that use intermediary agents. The vehicular scenario is not exempt of that problem either, specially if delay-sensitive/throughput-sensitive applications are to be deployed. Studies show that, for a NEMO-enabled configuration, the effective throughput of TCP applications is reduced at least in half, compared to the throughput perceived by applications that do not traverse the HA [4].

In addition, when V2V communications take place between NEMO-enabled vehicles in the same VCN, they end up using paths that traverse the fixed network instead of using the direct link between them. Experiments show that this effect could increase a regular RTT between two vehicles using 802.11b from 8ms up to approximately 40ms [5]. In general, sub-optimal paths to the CN result in increased packet overhead, and longer processing and end-to-end delays. Solutions that address the abovementioned issues for single-hop connections are described in section III-A.

On the other hand, although multi-hop connections are technically possible, not only they require nested configurations in NEMO-enabled vehicular networks, but also are unlikely to happen due to the following reasons: 1) given the vehicles high mobility, multi-hop paths are of a short-time duration (WiFi experiments in urban and freeway scenarios and analyses from simulated vehicular networks indicate a range between 10s and 40s for contact duration between two moving vehicles [6] [7]); and 2) the vehicle's restriction of configuring IP addresses

from another vehicle's IP prefix when they both belong to different administrative domains.

Instead of having vehicles configuring IP addresses from other vehicles, in multi-hop scenarios it is more feasible for MRs to use ad-hoc routing in a sub-IP layer in order to obtain IP addresses directly from the AR, as we will explain in section III-B.

#### A. *Single hop connections between VCN and fixed network*

The strategies in this category aim at avoiding the MR-HA tunnel. These strategies are illustrated in Fig.3 and described as follows.

1) *Tunnel establishment to CN*: This strategy resembles the RO technique used in MIPv6, with a tunnel being established between MR and CN. The requirement in this case is for the CN to support NEMO BS. The approach is especially useful when MNNs in the same mobile network communicate with only few CNs. MIRON [4] is an example of this strategy. This optimization method is offered to those MNNs that have no mobility protocol running on their own. Although the solution was evaluated with fixed nodes, it can be employed in vehicular scenarios. Results for delay-sensitive applications demonstrated a 5% reduction in packet overhead and nearly 50% increase in throughput;

2) *Tunnel establishment to Correspondent Router (CR)*: In this strategy, the closest router to the CN (i.e., the CR) sets a binding entry with the MR's information. The duties of the HA are then shifted to the CR. By assuming that traffic always traverses the CR, the path MR-CN is optimized. An additional procedure to locate the CR becomes necessary in order to establish the optimized tunnel. ONEMO [8] is a solution based on this strategy. The MR discovers the CR by sending a CR Discovery Request message to an anycast address derived from the CN's network prefix. Once the optimized tunnel is established, all the mobile network traffic bypasses the HA. The solution was tested in vehicular scenarios with TCP traffic and demonstrated a 44% reduction in RRT and 6% increase in throughput;

3) *Delegation to visiting nodes*: In this strategy, every mobility-capable MNN (i.e., the visiting node (VN)) configures a topologically valid CoA and activates its own RO using MIPv6. The MR forwards the packets coming from the visiting node to the AR without using the bi-directional tunnel to the HA\_MR. By surpassing the HA\_MR and the HA\_VN, the path between the VN and the CN is therefore optimized. An additional prefix delegation mechanism is required for the VN to be able to configure a valid CoA. An alternative mode of operation of MIRON [4] uses the abovementioned strategy. When the mobile network contains visiting nodes, they use address delegation with network access authentication to manage their own route optimization procedure in a secure manner;

4) *Intra-NEMO optimization*: This strategy aims to establish a direct path between MNN and CN when they are connected

to the same AR. By adopting this strategy, packets can be delivered with no use of resources from the fixed network. Usually, direct paths in the ad hoc network are established by a MANET routing protocol. Furthermore, there is a family of solutions—the so-called MANEMO—that explores the cooperation of MANET routing and NEMO.

Solutions in [5] [9] exemplify this strategy. Both are designed for vehicular scenarios and use Optimized Link State Routing Protocol (OLSR) to learn routes in the ad hoc network. They use a policy-based routing mechanism at the MR to select a NEMO-path or a MANET-path. Criteria such as bandwidth and RTT are used to select the optimal path. The test bed of both solutions involved moving vehicles. Results in [9] showed an improvement in path selection based on available bandwidth for UDP traffic. Accordingly, in [5] the experiments demonstrated a 26% reduction in the total RTT.

Another example is provided in VARON [10]. This solution aims to improve the delay and throughput for inter-vehicle communications while providing security. When the RO is activated, it establishes a path using the ad hoc routing protocol (ARAN) and performs a secure hop-by-hop binding procedure that uses cryptographically generated addresses. Simulation results in a vehicular environment showed that the TCP throughput of VARON does not improve for sparse scenarios, but outperforms by up to 4 times the one obtained by NEMO BS in dense scenarios.

#### B. *Multi-hop connections between VCN and fixed network*

What is intended by techniques in this category is that packets coming from nested MRs do not suffer from extra encapsulations at intermediate MRs, so that the pass through multiple HAs before reaching the CN is avoided. As mentioned before, the use of sub-IP ad hoc routing is a more feasible way to address this issue if a multi-hop path is established to reach the fixed network. This strategy is illustrated in Fig.4 and explained as follows.

*MANEMO*: In case of packets coming from nested MRs and destined to external nodes, an ad hoc sub-IP routing is used to forward IP packets through the multi-hop path, in a way that it creates a virtual link between the vehicle and the AR, without processing of IP headers at intermediate vehicles. The packets are then forwarded from the AR to the proper HA and then delivered to the CN. For the case of packets destined to nodes in the same ad hoc network, the strategy described in section III-A-4 is employed.

A MANET-centric solution that applies NEMO in VCN is presented in [11]. To eliminate the nesting problem, the scheme uses sub-IP geographic routing. Once a nested MR encapsulates a packet, the sub-IP layer builds a geo-header pointing to the AR. This geo-header is used to forward the packet until the AR is reached. Consequently, from the IP layer's perspective, the nested configuration is hidden, emulating a direct link between the AR and the nested MR.

#### C. *Contrast of the different RO solutions and discussion*

A qualitative comparison of the surveyed works is presented in Table I. Here, we discuss how those solutions address the

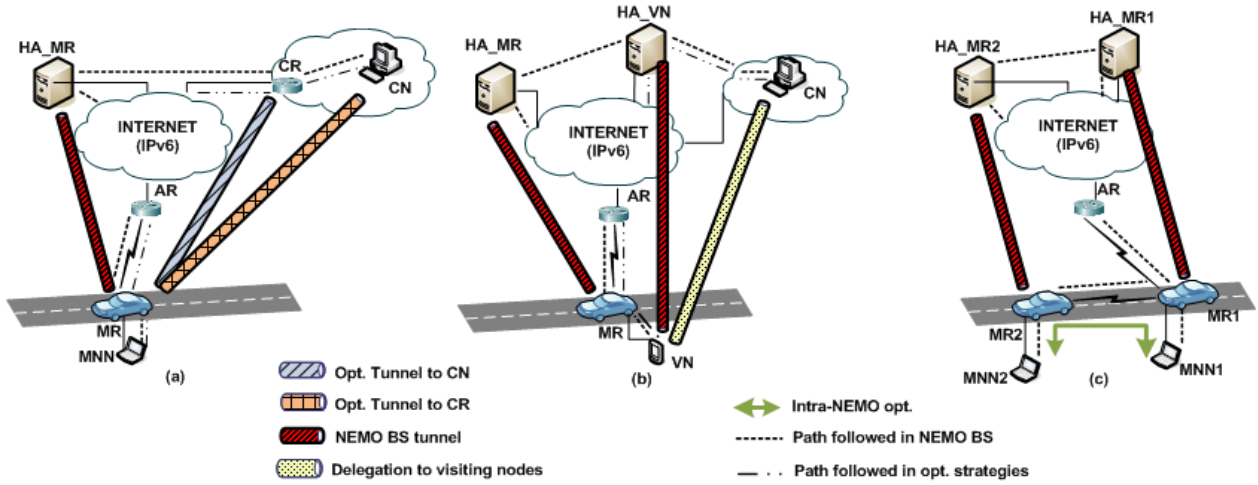

Fig. 3: Optimization of routes to reach the CN in single hop communications

specific requirements identified in VCN.

Most of the RO solutions combine several strategies to achieve optimization of NEMO. In general, all of them meet the requirement of improving network performance metrics such as end-to-end delay and packet efficiency. Nonetheless, there are also tradeoffs, specially in adaptability and processing delay. To focus on requirements 5 to 10 in section II, the solutions greatly differ from one another in the level in which those requisites are met.

One of the issues affecting most of the RO solutions relates to privacy protection. The ones that require the intermediate MRs to inspect or modify the BU signalling, or to propagate unprotected MNPs outside of the mobile network, do not fulfill this requirement. A good example of MNP's protection is provided by [4] [10]. Moreover, the MNP ownership has to be validated, and the strategies based on optimization to the CN/CR do not have the mechanisms to do such validation. Given that a vehicular scenario is formed by independent vehicles acting as mobile networks, it is very important to guarantee that no entity can use others' MNP to impersonate them. In terms of separability and multi-homing, many of the presented solutions could be easily adapted to support multiple CoA registration, and thus fulfill those requirements. In [5] for example, that extension is already included and the solution is evaluated using multiple active egress interfaces.

Solutions that determine the CN's location by means of topological or geographical information have shown to be able to use better paths. Therefore, with the use of geo-routing, solutions may react faster to topology changes and may exchange IP-related signalling with the AR (e.g., RA messages) regardless of network configurations. Moreover, given the geographic features available in VCN, one would expect that solutions based on strategies III-A-4 and III-B become natural for vehicular scenarios.

Finally, although proposals to establish a distributed system of HAs exist (see Global HA-HA protocol in draft-wakikawa-mext-global-haha-spec-01.txt [2]), none of the solutions that traverse at least one HA evaluate their performance by selecting the closest HA. If this were achieved, a more optimized

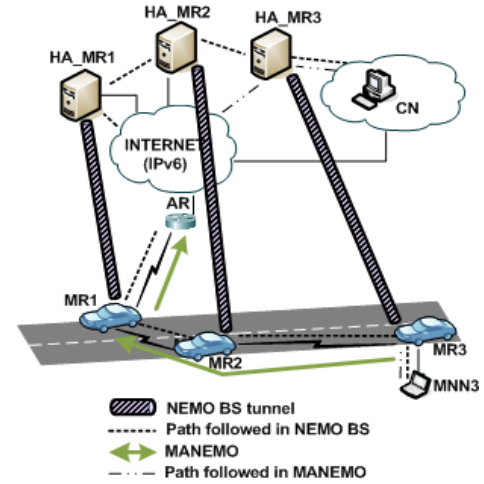

Fig. 4: Optimization of routes to reach the CN in multi-hop communications

route could be used (the distance MR-HA is reduced), and the solution could be more reliable and robust.

In the following section, we outline open research issues for IP mobility in VCN and provide some examples of ongoing research in this regard.

#### D. NEMO BS in heterogeneous vehicular access networks

A vehicle equipped with different radio interfaces may connect, sequentially or simultaneously, to dissimilar access networks. At first, NEMO BS was defined to register one single CoA with the HA, which was preventing the possibility to have more than one connection to different IP networks in the mobile network. However, a new standard named Multiple Care of Address Registration has been adopted to fix this problem (RFC 5648 [2]). An analysis of multihoming in network mobility support can be found in RFC 4980 [2].

The architecture of different access technologies is not yet transparent for the adoption of NEMO BS. A gap exists between some network architectures, such as LTE, and the

Solution	RO. Strategy	Nested NEMO opt.	MR-CN external opt.	V2V opt.	Separability	Security	Multi-homing	Addressing Management	Signaling load
<b>ONEMO</b> [8]	Proxy-MR, tunnel to CR	Yes	Yes	Yes	No	No	Supports mCoA configuration	Same as NEMO BS with TLMR's CoA announced to child-MRs	Independent of nesting level
<b>MIRON</b> [4]	Tunnel to CN, deleg. to visiting nodes/MR	Yes	Yes	No	Not restricted	Yes	Not restricted	Valid CoA delegation to MRs using PANA and DHCPv6	Grows linearly with # of opt. (independent of level of nesting). Generated by addr. deleg. mechanism for VMN/nest. scenarios.
<b>Converged MANEMO</b> [9]	Intra-NEMO opt., MANEMO	Yes	No	Yes	Yes	No	Yes	MNP announced in OLSR	Independent of nesting level
<b>Geo VANEMO</b> [11]	MANEMO	Yes	No	Yes	Not restricted	No	Not restricted	MNPs announced to the routing protocol	Independent of nesting level. Extra tunnel at the sub-IP layer
<b>VARON</b> [10]	Intra-NEMO opt.	No	No	Yes	Not restricted	Yes	Yes	MNPs announced to the routing protocol	Generated by the cryptographic system
<b>Simultan. MANEMO</b> [5]	Intra-NEMO opt.	No	No	Yes	Yes	No	Yes	MNPs announced to the routing protocol, mCoA support.	Generated by high frequency OLSR messages

TABLE I: Comparison of optimized network mobility solutions for VCN

entities defined by NEMO BS to provide IP mobility. In draft-perkins-mext-hatunaddr [2], the author proposes to modify the HA, so that the control plane and data plane are split to match the 4G protocol elements. However, an adoption of network-based protocols, such as Proxy Mobile IPv6 (RFC 5213 [2]), is more likely to happen among LTE vendors, since this could simplify the stack of protocols at the MR, while retaining full control of the IP mobility at the operator [12].

Whether to use host-based mobility with NEMO BS, or network-based mobility with Proxy MIPv6, roaming through heterogeneous networks is still challenging in terms of the handover delay and the performance perceived by users moving at vehicular speeds. An example of different handoff techniques that address these problems, and target vehicular mobility in multi-tier multi-hop wireless mesh networks is presented in [13].

#### IV. OPEN RESEARCH ISSUES

##### *Anchor Point location for VCN*

Given the wide extensions in which VCN are deployed, the vehicle's home network becomes a relative concept, which makes it difficult to indicate what the best location for the HA is. Proposals such as the aforementioned Global HA-HA protocol are more suitable for VCN, since they allow the geographical distribution of HAs. Moreover, although the standard NEMO includes a modified version for dynamically discovering the home agent address (DHAAD), this mechanism is designed only for environments in which security is not a requisite (see draft-dupont-mext-dhaad-harmful-00.txt [2]). Therefore, further studies on these aspects are also required. An interesting shift of paradigm is presented in [12], in which the vehicle's home network

is matched with the visited access network's administrative domain, and network-based mobility (based on Proxy MIPv6) is used instead of NEMO BS.

##### *Use of geographic information in RO*

One salient characteristic of VCN is that they are rich in geographical features. Beacons transmitted by OBUs carry information such as location, direction, speed, and acceleration. Such information is used by novel routing protocols that forward packets based on geographical locations, and that have been proved to fit well in vehicular scenarios. However, it is also possible to explore the utilization of this information to benefit the handover events and RO for IP mobility. The prediction of handovers events, based on mechanisms that integrate probabilistic methods and location information, could boost the mobility performance of IP mobility solutions.

##### *Security and privacy*

This is still a pending requisite to be addressed by many IP mobility and RO solutions. Current standards rely on IPSec for security, but there have been reports by vendors and implementors about implementation and inter-operability issues of IPSec in MIPv6/NEMO BS<sup>4</sup>. Moreover, many IP mobility and RO solutions neglect the processing delay and overhead caused by IPsec, even though the mechanism is defined as mandatory. Therefore, it is necessary on one hand,

<sup>4</sup>The difficulties in the IPSec implementations for MIPv6 are identified as one of the major barriers for the industry to widely adopt MIPv6. The exploration of alternative security mechanism for MIPv6 and NEMO BS has been included in the new charter of MEXT WG (<https://datatracker.ietf.org/wg/mext/charter/>) as a result of these findings.

to evaluate more solutions that actually implement IPsec as part of the mechanism, and on the other hand, to explore alternative security mechanisms that could incentive the rapid deployment of IP mobility in VCN.

Finally, all of the ownership authentication for network prefixes, privacy protection, and confidentiality of the information need to be further explored in V2I and V2V scenarios [14].

### **Role of vehicular mobility models in RO**

Simulation tools are a popular and cost-effective option for the evaluation of new protocols in VCN. Different mobility models that resemble the behavior of vehicles in highways and urban scenarios are currently integrated in the simulation phase. However, it is important to determine the extent to which the mobility model affects the results obtained by simulations. Studies have shown that different mobility models lead to dissimilar network protocols performance [7]. If a real test bed is not available, more realistic mobility models should be employed at the moment of evaluation of new IP mobility and RO solutions.

### **Addressing allocation scheme**

NEMO BS allows for two different forms of MNP registration: 1) implicit, in which both MR and HA know beforehand the assigned MNP; and 2) explicit, in which the MR explicitly sends the MNP in the binding update. However, the VCN may involve millions of nodes, and static configuration does not escalate in such large-size networks. A protocol to dynamically assign MNP to mobile networks has been recently approved to become an RFC (see draft-ietf-mext-nemo-pd-07 [2]), and its impact on RO solutions and security needs to be further studied. Furthermore, the integration of geographic addresses and IPv6 is another challenge to be addressed. Some advances in this topic are presented in [15].

### **Impact of VCN market penetration**

VCN rely on the deployment of in-vehicle and on-road communications equipments. The pace at which the equipments penetrate the market will highly affect the performance of the IP mobility solutions, which employ anchor points located at the infrastructure side. Therefore, the network-wide connectivity plays an important role in the solutions' performance. Moreover, the distribution of equipped vehicles could be highly variable even for a contained geographic area. In the hypothetical case that all new vehicles were fully equipped for VCN, they would be mixed with the existent fleet of vehicles that, in contrast, will follow a slow and gradual adoption process [16]. Therefore, IP mobility solutions should handle the different market penetration rates of VCN equipments over the short, medium, and long term.

## V. CONCLUSION

This article has identified several design challenges and special requirements for network mobility support in VCN. It has also provided qualitative comparisons of the strategies

and solutions proposed to date to optimize the performance of NEMO BS in vehicular scenarios and outlined some of the main open research challenges related to the IP mobility problem in VCN. Possible approaches to address these challenges and the related ongoing research have been discussed.

### ACKNOWLEDGMENTS

The authors would like to thank Ahmad Dhaini and all the anonymous reviewers for their insightful feedback on this work. This work has been partially supported by Universidad Icesi and Colfuturo, Colombia, and ORF-RE, Ontario, Canada.

### REFERENCES

- [1] V. Devarapalli, R. Wakikawa, A. Petrescu, and P. Thubert, "Network Mobility (NEMO) Basic Support Protocol," *IETF RFC 3963*, January 2005. [Online]. Available: [www.ietf.org/rfc/rfc3963.txt](http://www.ietf.org/rfc/rfc3963.txt)
- [2] IETF, "Internet drafts and RFC's," Aug. 24, 2010. [Online]. Available: <https://datatracker.ietf.org/> [Accessed: Aug. 31, 2010]
- [3] E. Perera, V. Sivaraman, and A. Seneviratne, "Survey on network mobility support," *SIGMOBILE Mob. Comput. Commun. Rev.*, vol. 8, no. 2, pp. 7–19, 2004.
- [4] M. Calderon, C. J. Bernardos, M. Bagnulo, I. Soto, and A. de la Oliva, "Design and Experimental Evaluation of a Route Optimization Solution for NEMO," *IEEE J. Sel. Areas Commun.*, vol. 24, no. 9, pp. 1702–1716, 2006.
- [5] T. Manabu, O. Mehani, and T. Ernst, "Simultaneous Usage of NEMO and MANET for Vehicular Communication," in *Proc. of TridentCom '08*, 2008, pp. 1–8.
- [6] K. Seada, "Insights from a Freeway Car-to-Car Real-World Experiment," in *WiNTECH '08*. ACM, 2008, pp. 49–56.
- [7] M. Fiore and J. Häri, "The Networking Shape of Vehicular Mobility," in *Proc. MobiHoc '08*. ACM, 2008, pp. 261–272.
- [8] M. Watari, R. Wakikawa, T. Ernst, and J. Murai, "Optimal Path Establishment for Nested Mobile Networks," in *IEEE 62nd VTC-2005-Fall*, vol. 4, pp. 2302–2306.
- [9] K. Okada, R. Wakikawa, and J. Murai, "MANET and NEMO Converged Communication," in *Technologies for Advanced Heterogeneous Networks II*, ser. LNCS. Springer Berlin / Heidelberg, 2006, vol. 4311, pp. 235–251.
- [10] C. J. Bernardos, I. Soto, M. Calderon, F. Boavida, and A. Azcorra, "VARON: Vehicular Ad hoc Route Optimisation for NEMO," *Computer Communications*, vol. 30, no. 8, pp. 1765–1784, 2007.
- [11] R. Baldessari, W. Zhang, A. Festag, and L. Le, "A MANET-centric Solution for the Application of NEMO in VANET Using Geographic Routing," in *Proc. TridentCom '08*, 2008, pp. 1–7.
- [12] I. Soto, C. J. Bernardos, M. Calderon, A. Banchs, and A. Azcorra, "Nemo-enabled Localized Mobility Support for Internet Access in Automotive Scenarios," *IEEE Commun. Mag. - [Topics in automotive networking]*, vol. 47, no. 5, pp. 152–159, 2009.
- [13] A. Giannoulis, M. Fiore, and E. W. Knightly, "Supporting vehicular mobility in urban multi-hop wireless networks," in *Proc. MobiSys '08*. ACM, 2008, pp. 54–66.
- [14] H. Zhu, R. Lu, X. Shen, and X. Lin, "Security in service-oriented vehicular networks," *IEEE Wireless Commun.*, vol. 16, no. 4, pp. 16–22, 2009.
- [15] R. Baldessari, C. J. Bernardos, and M. Calderon, "GeoSAC - Scalable Address Autoconfiguration for VANET Using Geographic Networking Concepts," in *IEEE PIMRC*, 2008, pp. 1–7.
- [16] F. Bai and B. Krishnamachari, "Spatio-Temporal Variations of Vehicle Traffic in VANETs: Facts and Implications," in *VANET '09*. ACM, pp. 43–52.

**Sandra Céspedes U.** received B.Sc.(Hons. 2003) and Specialization degrees in Telematics Engineering and Management of Information Systems (2007) from Icesi University, Colombia. She works as lecturer and researcher at Icesi University since 2005, and currently is working towards

her Ph.D. degree with the Department of Electrical and Computer Engineering at the University of Waterloo, Canada. Her current research interests include mobility management, wireless networks routing, and vehicular ad hoc and sensor networks

**Xuemin (Sherman) Shen** [M'97,SM02, F09] received a B.Sc. (1982) degree from Dalian Maritime University, China, and M.Sc. (1987) and Ph.D. degrees (1990) from Rutgers University, New Jersey, all in electrical engineering. He is a professor and University Research Chair, Department of Electrical and Computer Engineering, University of Waterloo. His research focuses on mobility and resource management, UWB wireless networks, wireless network security, and vehicular ad hoc and sensor networks. He served as an Area Editor for IEEE Transactions on Wireless Communications and Editor-in-Chief for Peer-to-Peer Networks and Applications. He is a Fellow of Engineering Institute of Canada, a registered Professional Engineer of Ontario, Canada, and a Distinguished Lecturer of the IEEE Communications Society.

**Christian Lazo-Ramirez** received a Ph.D. in Telematics Engineering from the Universidad de Vigo, Spain (2008). He is an auxiliary professor in the Department of Computer Science at the Universidad Austral de Chile (UACH), Valdivia, Chile. His research interests are in the field of new generations networks, ad hoc and sensors networks, IP protocols in heterogeneous mobile communications and the Internet of things.