

## First-order Fréedericksz transition in the presence of light-driven feedback in nematic liquid crystals

M. G. Clerc, S. Residori, and C. S. Riera

*Institut Non Linéaire de Nice, UMR 6618 CNRS-UNSA, 1361 Route des lucioles, F-06560 Valbonne, France*

(Received 30 January 2001; published 24 May 2001)

We show that feedback, which introduces a dependence of the electric field on the liquid-crystal director, renders the Fréedericksz transition first order. Experimentally, the feedback is introduced as a light loop in a liquid-crystal light valve. Theoretically, we include the feedback term into the Frank free energy and we derive an amplitude equation that is valid close to the transition. The theoretical description is in qualitative agreement with the experimental observations. Depending on the values of the feedback parameters, both theory and experiment exhibit bistability, propagation of fronts, and a Maxwell point.

DOI: 10.1103/PhysRevE.63.060701

PACS number(s): 42.70.Df, 05.45.-a, 05.70.Np, 64.60.-i

Liquid crystals under the influence of electric and magnetic fields exhibit a large variety of complex dynamical behavior, such as electroconvection, pattern formation [1], spirals [2,3], and optical instabilities [4]. One of the most well-studied phenomena in the physics of liquid crystals is the field-induced distortion of a nematic liquid-crystal film, called the Fréedericksz transition (FT) [5]. For a nematic film, FT is usually a second-order transition [6]. Recently, a new type of Fréedericksz transition has also been reported for a nematic liquid crystal under elliptic shear [3]. The latter transforms the transition into a Hopf bifurcation thereby allowing for the observation of waves and spirals. The possibility of modifying FT into a first-order transition has been considered, either through the simultaneous application of electric and magnetic field [7] or through the action of an optical field [8], for liquid crystals possessing a very large optical anisotropy. However, in both cases, an experimental verification is difficult to attain, especially over a large area of the liquid crystal film.

In this Rapid Communication, we demonstrate that FT becomes first-order for a planar aligned nematic film in which a feedback mechanism leads to a dependence of the applied electric field on the liquid-crystal director. Experimentally, we realize this feedback by means of a liquid-crystal light valve (LCLV) [9]. A simplified scheme of the setup is shown in Fig. 1. A LCLV consists essentially of a nematic liquid-crystal film sandwiched between a glass and a photoconductive plate over which a dielectric mirror is deposited. Coating of the two bounding plates induces a planar anchoring (nematic director  $\vec{n}$  parallel to the walls) of the liquid-crystal film. Moreover, transparent electrodes covering the two plates permit the application of an electric field across the liquid-crystal layer. The photoconductor behaves like a variable resistance, which decreases for increasing illumination. The light-driven feedback is obtained by sending back onto the photoconductor the light which has passed through the liquid-crystal layer and has been reflected by the dielectric mirror. The light beam experiences a phase shift which depends on the liquid-crystal orientation. By inserting a polarizer, phase shifts are converted into intensity variations which modulate the illumination onto the photoconductor, and hence the effective voltage applied to the liquid-crystal film.

At variance with the all-optically induced FT, in the LCLV the interaction between the optical field and the liquid crystal is mediated by the photoconductor, leading to a large amplification of the dependence of the applied voltage on the liquid-crystal reorientation. Because of this feedback enhancement, we are able to observe a first-order FT for a relatively small value of the input light intensity ( $I_{in} \approx 0.9$  mW/cm<sup>2</sup>) and over a large area of the liquid crystal sample ( $A \approx 1$  cm<sup>2</sup>). This opens the possibility of investigating, in a nematic liquid-crystal sample, spatial phenomena such as spot nucleation, front propagation, and dynamics, which are very similar to those observed in excitable chemical systems [10].

We explain the transformation of the FT into a first-order transition from fundamental principles, starting from the classical description in terms of the Frank free energy. We express the liquid-crystal free energy by taking into account the effect of feedback as well as the usual nonlinear elastic terms. Then, close to the FT, we derive an amplitude equation which shows that, depending on the mutual orientation

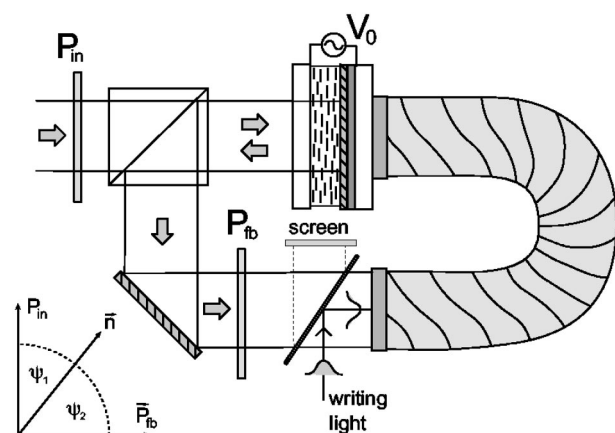

FIG. 1. Experimental setup. Two confocal lenses, not displayed in the scheme), provide a 1:1 image-forming system from the front side of the LCLV to its rear side. The optical feedback loop is closed by a fiber bundle, which is aligned in order to avoid any rotation or shift.  $P_{in}$  and  $P_{fb}$  are, respectively, the input and feedback polarizer. Their orientation with respect to the liquid-crystal director is indicated in the left bottom of the figure.

of the light polarization and the liquid-crystal director, the FT can become first-order.

For a nematic liquid-crystal layer on which an electric field is applied, the dynamical equation for the director reads [6]

$$\gamma \vec{n} \times \partial_t \vec{n} = -\vec{n} \times \frac{\delta \mathcal{F}}{\delta \vec{n}}, \quad \vec{n} \cdot \vec{n} = 1, \quad (1)$$

where  $\gamma$  is the rotational viscosity, and  $\mathcal{F}$  the Frank free energy which is expressed by

$$\mathcal{F} = \frac{1}{2} \int K_1 (\vec{\nabla} \cdot \vec{n})^2 + K_2 [\vec{n} \cdot (\vec{\nabla} \times \vec{n})]^2 + K_3 [\vec{n} \cdot (\vec{\nabla} \times \vec{n})]^2 - \epsilon_{\perp} \vec{E}^2(\vec{n}) - \epsilon_a [\vec{n} \cdot \vec{E}(\vec{n})]^2 d\vec{r}. \quad (2)$$

$K_i$  are the elastic constants of the liquid crystal,  $\epsilon_a$  the dielectric anisotropy, and  $\epsilon_{\perp}$  the perpendicular dielectric permeability. In the vicinity of the FT, it is reasonable to neglect backflow effects in the layer [6]. In the presence of feedback, the electric field depends on the liquid-crystal director, which adds new terms in the expression for the dynamical equation. For the sake of simplicity, we assume  $K_1 = K_2 = K_3 = K$ , leading to

$$\begin{aligned} \gamma \partial_t \vec{n} = & K [\nabla^2 \vec{n} - \vec{n} (\vec{n} \cdot \nabla^2 \vec{n})] + \epsilon_a (\vec{n} \cdot \vec{E}) [\vec{E} - \vec{n} (\vec{n} \cdot \vec{E})] \\ & + \frac{\epsilon_{\perp}}{2} \frac{\partial \vec{E}^2}{\partial \vec{n}} - \frac{\epsilon_{\perp}}{2} \left( \vec{n} \cdot \frac{\partial}{\partial \vec{n}} \right) \vec{E}^2 \\ & + \frac{\epsilon_a}{2} (\vec{n} \cdot \vec{E}) \vec{n} \cdot \left[ \left( \vec{n} \cdot \frac{\partial}{\partial \vec{n}} \right) \vec{E} \right]. \end{aligned} \quad (3)$$

The extra terms containing the derivatives of the electric field result from the feedback, which couples the applied electric field to the director reorientation, and are responsible for changing the classic supercritical character of the FT into a subcritical one.

The experimental setup, displayed in Fig. 1, consists of a LCLV with optical feedback, which is a system well-known for optical pattern formation [11]. In the present experiment the optical loop is designed in such a way that the light beam experiences no diffraction as well as no geometrical transformation, so that no pattern is formed. The light intensity  $I_w$  reaching the photoconductor is given by [11]

$$I_w = |\cos \psi_1 \cos \psi_2 + \sin \psi_1 \sin \psi_2 e^{-i\beta \cos^2 \theta}|^2 I_{in}, \quad (4)$$

where  $\beta \equiv 2kd\Delta n \cos^2 \theta$ ,  $\theta$  being the liquid crystal reorientation angle, is the overall phase shift experienced by the light traveling forth and back through the liquid-crystal layer,  $I_{in}$  is the input intensity,  $\psi_1$  and  $\psi_2$  are the angles formed by the input and feedback light polarization with the liquid crystal director  $\vec{n}$ , respectively,  $k = 2\pi/\lambda$  is the optical wave number,  $d$  is the thickness of the liquid crystal layer and  $\Delta n$  is the difference between the extraordinary ( $\parallel$  to  $\vec{n}$ ) and ordinary ( $\perp$  to  $\vec{n}$ ) index of refraction of the liquid crystal [6].

In our experiment,  $\beta \approx 120$  since  $\lambda = 633$  nm,  $\Delta n = 0.2$ ,  $d = 30$   $\mu\text{m}$ , and we fix  $\psi_1 = \psi_2 = 45^\circ$  in order to maximize the birefringence of the LCLV.

The voltage  $V_0$  applied to the LCLV is sinusoidal of frequency  $f = 20$  kHz, much larger than the liquid-crystal response time and the typical times for liquid-crystal hydrodynamic instabilities [1]. This way, liquid crystals are sensitive only to the rms value of the applied voltage and thereby perform only a static molecular reorientation. Hence, dynamical effects, such as backflow, are avoided and the phase transition is a pure FT [6].

The total electric field applied to the liquid-crystal layer depends on the response of the photoconductor to the right intensity  $I_w$  and to the voltage applied to the liquid-crystal layer ( $V_0 = E_0/d$ ). In the experiment,  $V_0$  is used as the bifurcation parameter. As the light intensity is sufficiently small, the response of the photoconductor is linear. Thus, the total electric field reads  $E(n) = E_0 + \alpha I_w(\vec{n})$ , where  $\alpha \approx 4$  is a phenomenological parameter that we can evaluate from the experimental characteristics of the LCLV (measuring  $I_w$  in  $\text{mW}/\text{cm}^2$ ).

After substituting Eq. (4) in the expression for the electric field, we obtain  $E(n) = E_0 + A + B \cos(\beta \cos^2 \theta)$ , where  $A = \frac{1}{4} [\cos 2(\psi_1 - \psi_2) + \cos 2(\psi_1 + \psi_2) + 2] \alpha I_{in}$  and  $B = \frac{1}{4} [\cos 2(\psi_1 - \psi_2) - \cos 2(\psi_1 + \psi_2)] \alpha I_{in}$ . Since the liquid crystals are aligned parallel to the walls (planar anchoring) and are submitted to a perpendicular electric field, we have  $\vec{E} = (0, 0, E)$  and  $\vec{n} = (n_x, 0, n_z)$ , with  $n_x^2 + n_z^2 = 1$ . By inserting  $E(n)$  in Eq. (3) and by means of standard bifurcation theory, we derive an amplitude equation for the first unstable Fourier mode,  $n_z = u(x, y) \sin(\pi z/d)$  and  $n_x = 1 - u^2 \sin^2(\pi z/d)/2$ , which describes the director orientation at the onset of the instability. The equation reads

$$\partial_t u = c_1 u + c_3 u^3 + c_5 u^5 + K \nabla_{\perp}^2 u, \quad (5)$$

where the coefficients  $c_1$ ,  $c_3$ , and  $c_5$  are given by

$$\begin{aligned} c_1 = & \gamma^{-1} \left( -\frac{K \pi^2}{d^2} + [A + E_0 + B \cos(\beta)] \{ \epsilon_a (A + E_0) \right. \\ & \left. + B [ \epsilon_a \cos(\beta) + 2 \epsilon_{\perp} \beta \sin(\beta) ] \} \right), \\ c_3 = & \gamma^{-1} \left( \frac{1}{3} \frac{K \pi^2}{d^2} - \frac{2}{3} \epsilon_a (E_0 + A)^2 + \frac{2}{\pi^2} \epsilon_{\perp} [2B \beta \sin(\beta)]^2 \right. \\ & - \frac{2}{3 \pi^2} (12\beta^2 \epsilon_{\perp} + \pi^2 \epsilon_a) [B \cos(\beta)]^2 \\ & + \frac{\beta}{\pi^2} [ \epsilon_a (8 + \pi^2) - \epsilon_{\perp} \pi^2 ] [A + E_0 + B \cos(\beta)] B \sin(\beta) \\ & \left. - \frac{4}{3 \pi^2} (6\beta^2 \epsilon_{\perp} + \pi^2 \epsilon_a) (E_0 + A) B \cos(\beta) \right), \end{aligned} \quad (6)$$

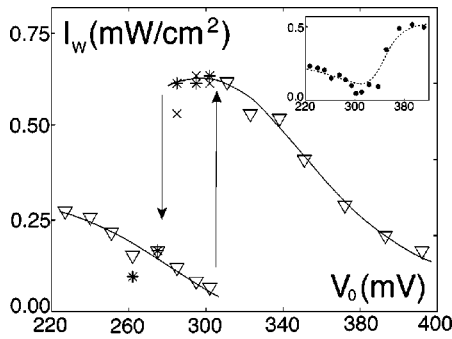

FIG. 2.  $I_w$  as a function of the rms values of the applied voltage  $V_0$ . Triangles correspond to increasing  $V_0$ ; cross and stars to decreasing  $V_0$ , with writing light off and on, respectively. In the inset, we plot  $I_w$  vs  $V_0$  in the absence of feedback.

$$c_5 = \gamma^{-1} \left[ \left( \frac{2B\beta}{\pi^2} \right)^2 [(4 + \pi^2)\epsilon_a - \pi^2\epsilon_\perp][\sin(\beta)^2 - \cos(\beta)^2] - \frac{B\beta}{12\pi^4} [192\beta^2\epsilon_\perp + (9\pi^2 + 64)\pi^2\epsilon_a](E_0 + A)\sin(\beta) - \left( \frac{2\beta}{\pi^2} \right)^2 [(4 + \pi^2)\epsilon_a - \pi^2\epsilon_\perp](E_0 + A)B\cos(\beta) - \frac{B^2}{12\pi^4} (9\pi^2 + 64)(\epsilon_a + 768\beta^2\epsilon_\perp)\beta\sin(\beta)\cos(\beta) \right].$$

When  $c_3$  is negative and of the order 1, Eq. (5) describes a second-order FT. The FT becomes first order when  $c_1$  and  $c_3$  are positive (and small), with  $c_5$  negative. This situation well describes, qualitatively, the experimental observations,  $c_3$  being a function of the polarizer angles, of the input intensity and of the voltage applied to the LCLV. In particular, we have verified that changes in the polarizer angles produce effects with the same sign in the theory and in the experiment. However, it is important to stress that the theoretical description of the transition is valid only in the asymptotic limit  $c_3 \sim (c_1)^{1/2}$ . Instead, a quantitative description of the experiment would require  $c_3 \sim 1$ , which cannot be obtained from an asymptotic analysis [13]. Henceforth we consider  $c_3 > 0$  and  $c_5 < 0$ .

In order to observe the FT, we measure the intensity  $I_w$  reaching the photoconductor. This is done by extracting a small portion of the feedback light and by sending it onto a photodiode. When the applied voltage  $V_0$  is below the threshold value for molecular reorientation,  $I_w$  has a value fixed by  $\beta$ . When reorientation occurs, we expect this value to change according to expression (4). We verify the validity of this prediction by measuring  $I_w$  in the absence of feedback; that is, by blocking the entrance of the fiber bundle with a black screen ( $A=B=0$ ). The measured  $I_w$  is displayed in the inset of Fig. 2, as a function of  $V_0$ . We can see that the FT takes place at  $V_0 \approx 3.2 V_{\text{rms}}$ . When we remove the blocking screen,  $I_w$  changes according to the liquid-crystal reorientation. This intensity change induces, in turn, a variation of the voltage across the liquid-crystal layer, and

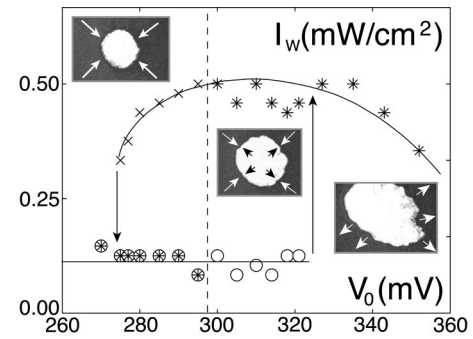

FIG. 3. Bistability and front propagation in the  $I_w$  vs  $V_0$  plot. Circles, dark state with writing light off; stars, white state with writing light off; crosses, white state with writing light on.

hence a further reorientation. Thus, feedback is established between the applied voltage and the liquid-crystal director.

In Fig. 2 we show  $I_w$  as a function of  $V_0$  and in the presence of feedback. The transition point is characterized by an abrupt change in the intensity, which reaches its maximum value. Notice that  $I_w$  is measured by a small area photodiode, i.e., it is a local measurement taken at the center of the feedback beam. By looking at the entire image of the feedback beam with a charge-coupled-device camera, we see that the transition point is characterized by a white spot developing over a dark background. In the course of time, the front of the white spot expands and the white state overcomes the dark one. For the amplitude equation, this represents the front solution between the unstable state  $u_0=0$  and the stable state  $u_\pm^2 = (-c_3 \pm \sqrt{c_3^2 - 4c_1c_5})/(2c_5)$ , a Kolmogorov-type front [14]. By further increasing the voltage, the LCLV birefringence changes and the white state becomes “gray” until the dark value is reached again. Successive transitions to the white state are present for larger values of the applied voltage. These states correspond to parameter values far from the FT [12], and are therefore ignored in this work.

By decreasing the voltage, we observe a hysteresis cycle. In order to determine the size of the bistable region, we inject an additional light spot (low power He-Ne laser) into the feedback loop. This acts as a small perturbation, triggering the transition from the dark state to the white one. The white state persists when we block the additional writing light, while it switches to the dark state if we perturb the feedback. In Fig. 2, the arrows delimit the region over which this writing-erasing procedure is robust. Notice that spatial inhomogeneities and other noise sources can influence the stability of the two states. Furthermore, just before the transition, there is an appreciable decrease of the intensity  $I_w$ . This is indeed a signature of the fact that we are approaching the transition point, where fluctuations become very large and light is diffused in all directions, in the same way as it occurs at the critical point for a liquid-vapor transition. This sort of critical opalescence [15], is responsible for the diminished efficiency of the light reflection from the LCLV.

As a signature of the bifurcation diagram of Eq. (5), a more detailed set of measurements is reported in Fig. 3 for a  $V_0$  range centered around the transition point and together

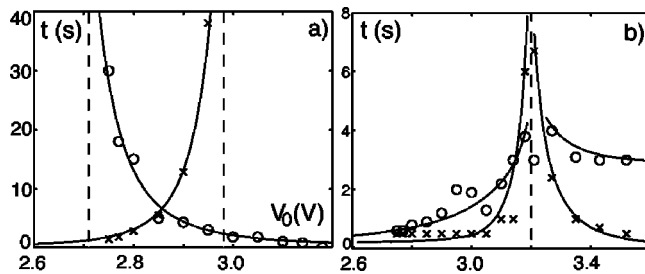

FIG. 4. (a)  $\tau_r$  (circles) and  $\tau_f$  (crosses) as a function of  $V_0$ ; (b)  $\tau_{on}$  (crosses) and  $\tau_{off}$  (circles) as a function of  $V_0$ .

with three representative images of the feedback field. These images show the direction of the front propagation, depending on the mutual stability of the white and the dark states. The dashed line marks the point at which the front propagation is zero, usually called the Maxwell point. Below this point the white state is less stable than the dark one and the white spot, once created by the writing light, contracts to zero. Above the FT point, the white spot nucleates spontaneously and its front expands until the white state covers all the background. In between, the front of the spot expands or retracts depending on the size of the perturbation.

The three crucial points, i.e., the beginning of the bistability, the Maxwell point and the FT point, are identified by the divergence of the response times. We show in Fig. 4 the response times measured for the same set of measurements reported in Fig. 3. In Fig. 4(a), we show the rise time  $\tau_r$ , needed for a white spot to develop once the writing light is switched on and the fall time  $\tau_f$  taken by the white spot to

disappear when the writing light is switched off. The divergence of the first one identifies the beginning of the bistable region, whereas the divergence of the second one corresponds to the Maxwell point. In Fig. 4(b) we show the rise  $\tau_{on}$  and fall  $\tau_{off}$  time when the feedback is switched respectively on and off. The divergence of these two times corresponds to the FT point. Correspondingly, in the amplitude equation (5), the beginning of the bistability is characterized by  $c_3^2 - 4c_1c_5 \geq 0$ ,  $c_1 < 0$ , the Maxwell point by  $c_3^2 = 16c_5c_1/3$  ( $c_1 < 0$ ), and the FT by  $c_1 = 0$ .

In conclusion, we have shown that an amplitude equation can be derived close to the FT for a nematic liquid-crystal layer in the presence of a light-driven feedback. We have demonstrated that, because of feedback, the FT can become first order. Our theoretical description is in a fair qualitative agreement with the experimental observations. The feedback is provided by the conversion of optical intensity (changing with the reorientation angle) into electric field (changing the reorientation angle) via a photoconductive transducer (LCLV). Bistability is very robust here and is present for a relatively wide range of the experimental parameters. Spatial dynamics of front propagation is also reported. A more detailed study of front propagation, critical droplet size, and pattern dynamics is in progress.

We are greatly indebted to P. Coulet and J.M. Gilli for fruitful discussions. We gratefully acknowledge G.L. Lippi for careful reading of the manuscript. This work has been supported by the ACI Blanche of the French Ministry of Research. One of us (M.G.C.) has benefited from the financial support from the Centro de Fisica No Lineal y Sistemas Complejos de Santiago.

- 
- [1] See, e.g., *Pattern Formation in Liquid Crystals*, edited by A. Buka and L. Kramer (Springer-Verlag, New York, 1996).
- [2] T. Frisch, S. Rica, P. Coulet, and J.M. Gilli, *Phys. Rev. Lett.* **72**, 1471 (1994).
- [3] T. Borzsonyi, A. Buka, A.P. Krekhov, O.A. Scaldin, and L. Kramer, *Phys. Rev. Lett.* **84**, 1934 (2000).
- [4] N.V. Tabiryan, A.V. Sukhov, and B. Ya. Zel'dovich, *Mol. Cryst. Liq. Cryst.* **136**, 1 (1985); G. Demeter and L. Kramer, *Phys. Rev. Lett.* **83**, 4744 (1999).
- [5] V. Fréedericksz and V. Zolina, *Trans. Faraday Soc.* **29**, 919 (1933).
- [6] P.G. de Gennes and J. Prost, *The Physics of Liquid Crystals*, 2nd ed. (Oxford Science Publications, New York, 1993); S. Chandrasekhar, *Liquid Crystal* (Cambridge, New York, 1992).
- [7] B.J. Frisken and P. Palffy-Muhoray, *Phys. Rev. A* **39**, 1513 (1989); **40**, 6099 (1989); S. Garg, S. Saeed, and U.D. Kini, *Phys. Rev. E* **51**, 5846 (1995).
- [8] S.D. Durbin, S.M. Arakelian, and Y.R. Shen, *Phys. Rev. Lett.* **47**, 1411 (1981); A.J. Karn, S.M. Arakelian, Y.R. Shen, and H.L. Ong, *ibid.* **57**, 448 (1986).
- [9] S.A. Akhmanov, M.A. Vorontsov, and V.Yu. Ivanov, *Pis'ma Zh. Éksp. Teor. Fiz.* **47**, 611 (1988) [*JETP Lett.* **47**, 707 (1988)].
- [10] D. Walgraef, *Spatio-temporal Pattern Formation* (Springer-Verlag, New York, 1997).
- [11] See, e.g., *Pattern Formation in Nonlinear Optical Systems*, edited by R. Neubecker and T. Tschudi, special issue of *Chaos, Solitons Fractals* **10** (4-5) (1999); F.T. Arecchi, S. Boccaletti, and P.L. Ramazza, *Phys. Rep.* **318**, 1 (1999), and references therein.
- [12] P.L. Ramazza, S. Residori, E. Pampaloni, and A.V. Larichev, *Phys. Rev. A* **53**, 400 (1996).
- [13] P. Manneville, *Dissipative Structures and Weak Turbulence* (Academic Press, San Diego, 1990).
- [14] M. Cross and P. Hohenberg, *Rev. Mod. Phys.* **65**, 851 (1993).
- [15] L. Mandel and E. Wolf, *Optical Coherence and Quantum Optics* (Cambridge University Press, New York, 1995).